

DRG 1.FLANGE

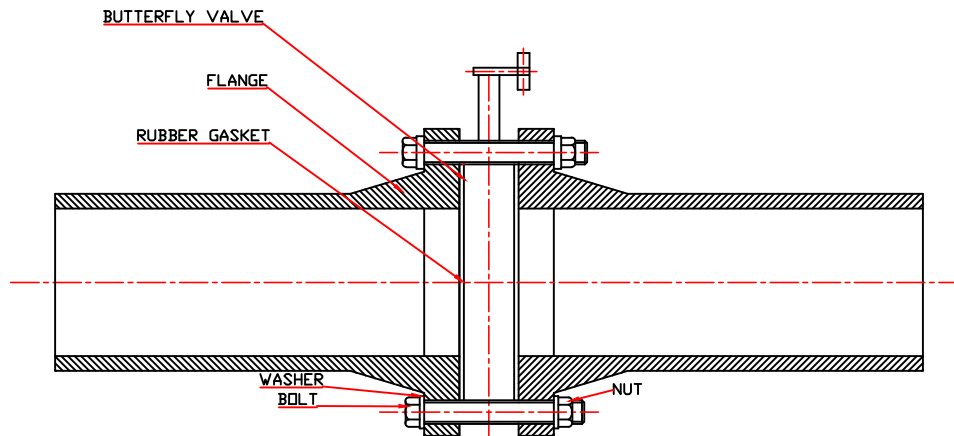

DRG 2. FLANGE AND VALVE ASSEMBLY

NOTES

- 1.MATERIAL-GLASS REINFORCED PLASTIC(GRP)
- 2.PRESSURE RATING PN10
- 3.DIMENSIONS-REFER TO THE TABLE BELOW
- 4.FLANGES ARE BACK FACED OR SPOT FACED TO ACCOMMODATE ANSI TYPE "A" PLAIN WASHERS,NARROW SERIES.
- 5.FLANGES TO BE SUPPLIED WITH A COMPLETE SET OF STAINLESS STEEL BOLTS.
- 6.NUMBER OF HOLES NOT SPECIFIED
- 7.FLANGES TO BE SUPPLIED WITH FITTING RUBBER GASKET WITH PRESSURE RATING PN10,THAT SITS INSIDE THE BOLT CIRCLE OF THE FLANGE.
- 8.FLANGES TO BE SUPPLIED WITH A FITTING WAFER BUTTERFLY TYPE ,ALL STAINLESS STEEL TRIM BODY AND DISC,RESISTANT TO CORROSIIVE GEOTHERMAL FLUIDS.
- 9.STAINLESS STEEL,BOLTS AND NUTS MINIMUM SIZE M20
- 10.DRILLED HOLE PATTERN AS PER ANSI B16.5,CLASS 150

11.DRG NOT TO SCALE

12. MINIMUM THICKNESS 8 mm

FLAT FACE GRP FLANGE				
DIMENSIONS(MM)				
TYPE	A	B	I/D	QNTY
1	45(MIN)	250(MIN)	DN250	8PCS(4SETS WHEN ASSEMBLED)
2	45(MIN)	250(MIN)	DN300	24PCS(12 SETS WHEN ASSEMBLED)

Item Ref.	Quantity	Title Name, Designation	Material	Dimension	
Designed by	Checked by	Approved by	DWG. NO.	Date	Scale
A. Dairo	D. Inald	Eng. Kutswe	KGN/GPD/VHG/03-2018-001	14/3/2018	Not to Scale

KENGEN

FLAT FACE GRIP FLANGE

1	Edition 0	Sheet 1/1
---	-----------	-----------